

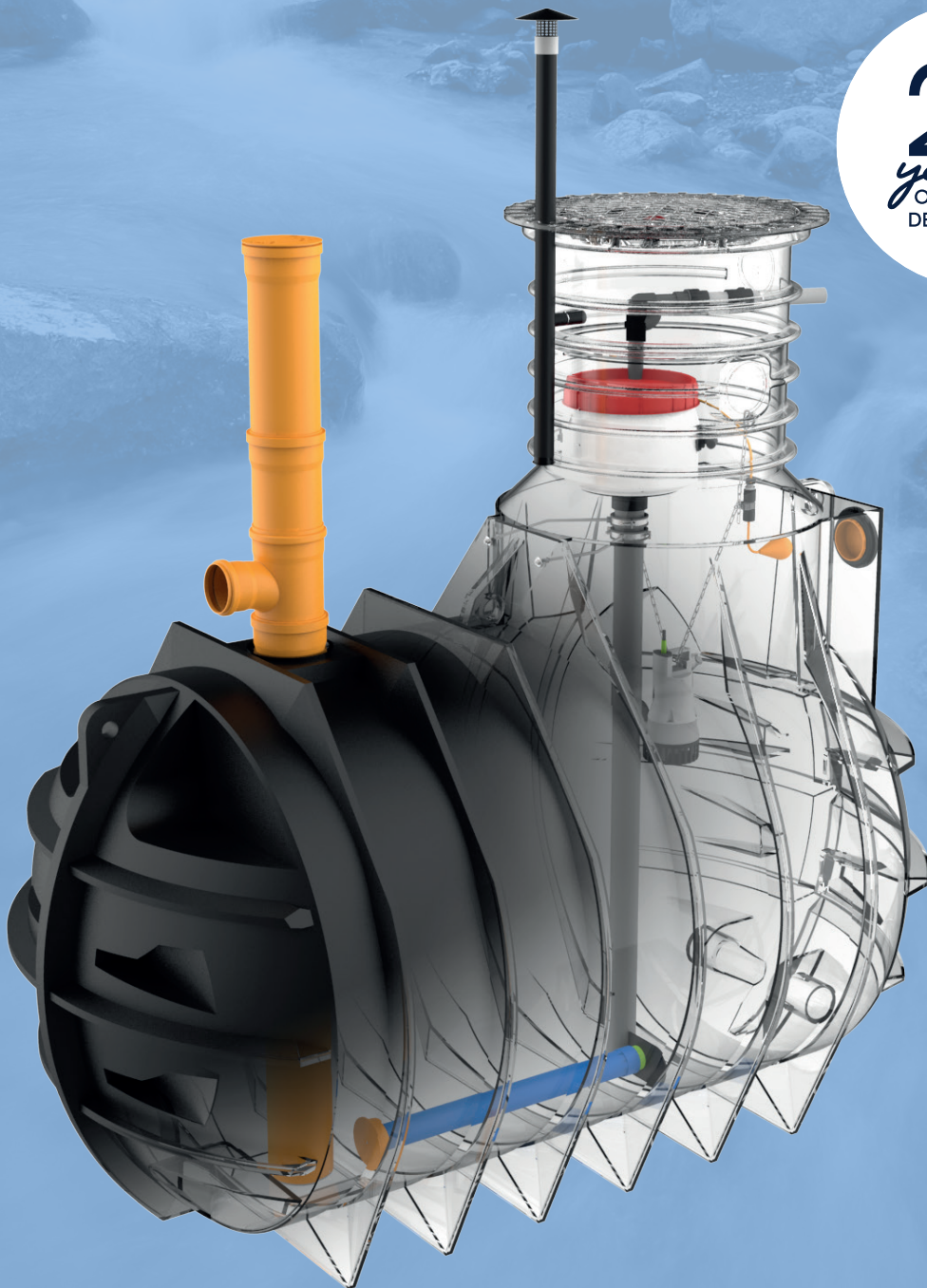

THE NEW GENERATION
OF DECENTRALISED
WASTEWATER TREATMENT

REWATEC[®]

Solido Smart SBR system



THE FUTURE OF SBR TREATMENT

The Rewatec Solido Smart from Premier Tech is a decentralised wastewater treatment plant and the perfect solution for residential and commercial projects where mains drainage is unavailable.

Serving up to 9 PE and fast becoming the industry's system of choice, Solido Smart SBR is a low-profile solution that treats wastewater with minimal impact on the environment.

Featuring a proven design and low installation costs, this system is available in gravity and integrated pumped-outlet models that are ideal for single dwellings and small communities.

SUPERIOR PERFORMANCE

The highly effective Solido Smart SBR is designed and tested in accordance with EN 12566-3, in compliance with S.R 66:2015.

	Final effluent quality
Biochemical oxygen demand (BOD)	< 10 mg/L
Total suspended solids (TSS)	< 20 mg/L
Ammonia (NH₃)	< 5 mg/L
Total nitrogen (TN) reduction	83%
Total phosphorus (TP) reduction	68%

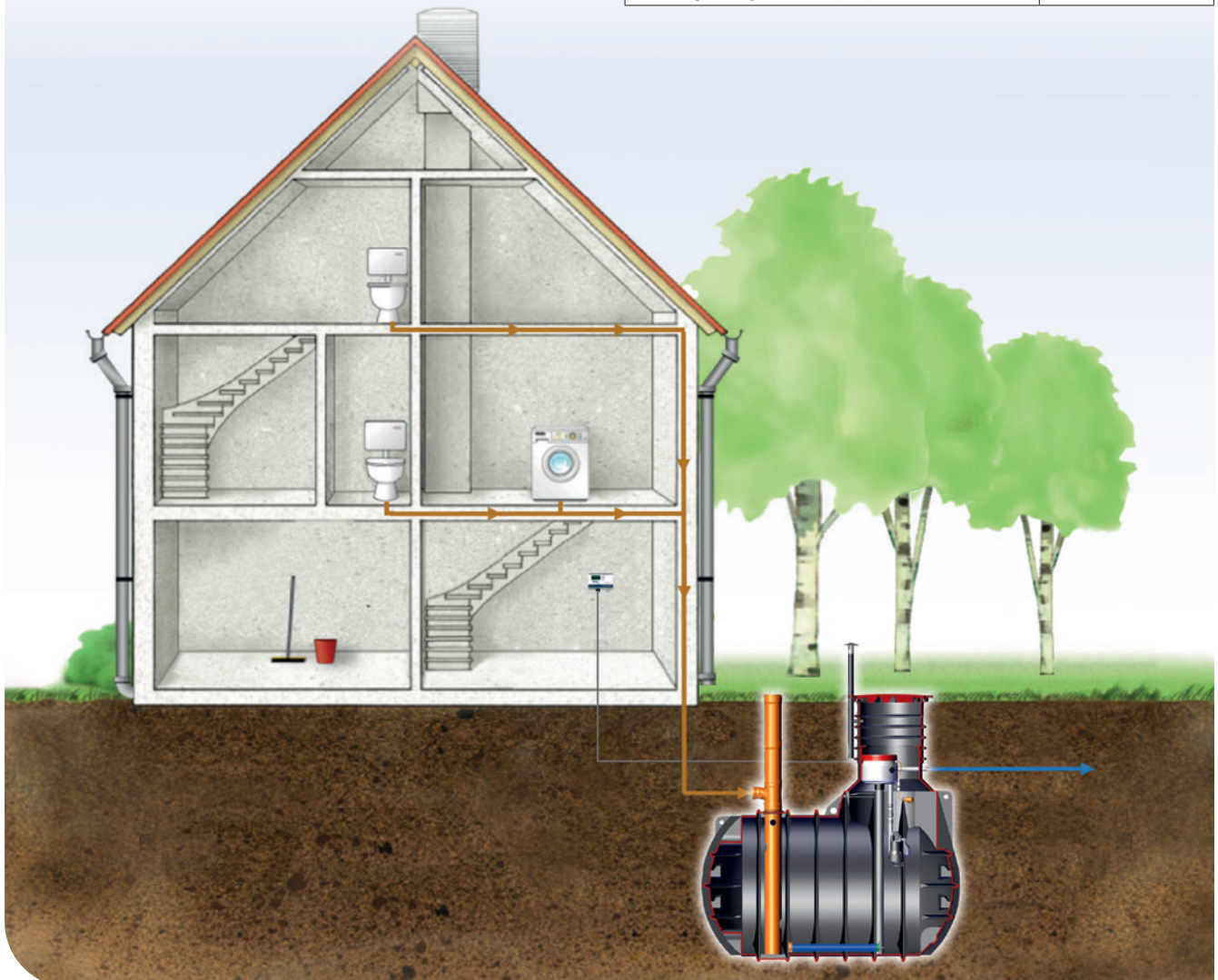

ADVANCED TECHNICAL QUALITIES

Solido Smart SBR makes decentralised wastewater treatment easier and more efficient than ever. Trust its high-quality design and durable components to provide long-term performance and peace of mind.

- Low operational and maintenance costs, offering long-term savings.
- Discreet and silent.
- Lightweight tank with minimal excavation depth and installation costs.
- Durable, recyclable, and impact-resistant polyethylene tank.
- Fully CE marked. Designed and tested in accordance with EN 12566-3.

HOW IT WORKS



Solido Smart SBR combines the benefits of an ultra-compact solution with the trusted performance of sequencing batch reactor technology. No primary treatment is needed. Instead, this system uses efficient aeration cycles to break down wastewater solids and provide oxygen to microorganisms that feed on organic pollutants. The process is simple, odourless, and effective – now and for the future.

Technology capsule

Safely houses the system's compressor to guarantee quiet and efficient performance. Requires only 0.80 kWh/d for 6 PE plants and 1.04 kWh/d for 9 PE plants.

Smart pipe

Slows incoming wastewater and simplifies inspections. Makes desludging safe and easy.

Tank

Seamless one-piece tank made from recyclable polyethylene. Comes with a standard 25-year warranty.



Clearwater pump

(Pumped outlet only)

Clearwater air lift

(Gravity outlet only)

Tube diffuser

Immediately supplies incoming wastewater with oxygen to ensure efficient and odourless treatment.

Prevents sludge loss and ensures high performance thanks to a patented self-flushing feature.

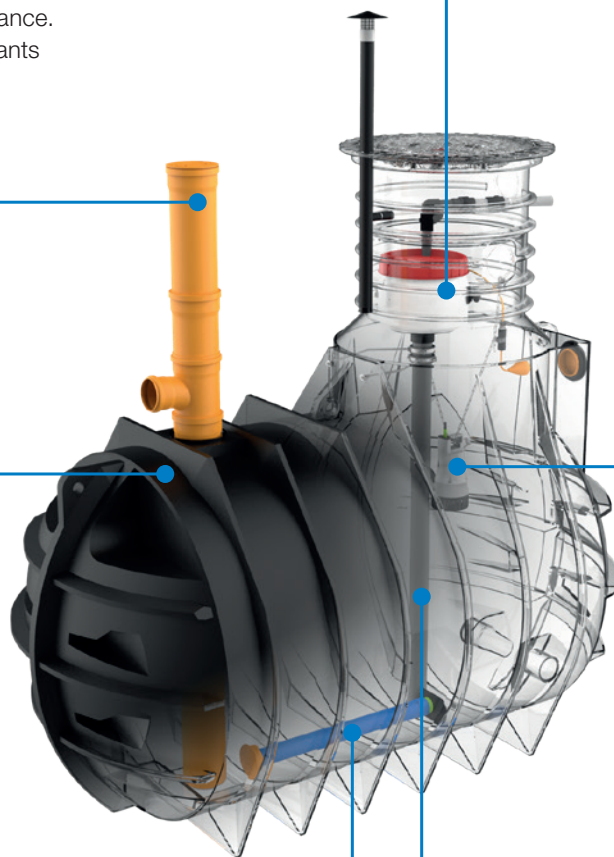

SPECIFICATIONS

	6 PE		9 PE	
Hydraulic capacity	max. 0.9 m ³ /d		max. 1.35 m ³ /d	
Discharge	Pumped	Gravity	Pumped	Gravity
Tank volume	3,000 L		4,500 L	
Length	2.42 m			
Width	1.42 m		1.79 m	
Height	2.06 – 2.47 m		2.34 – 2.75 m	
Inlet height from base	1.47 m		1.74 m	
Outlet height from base	1.73 m	1.40 m	2.06 m	1.73 m
Pipe diameter	110 mm			
Reference code	KEBL3026	KCBL3020	KEBL4526	KCBL4520

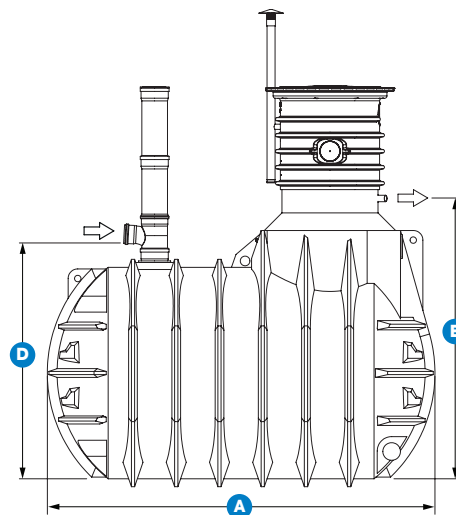
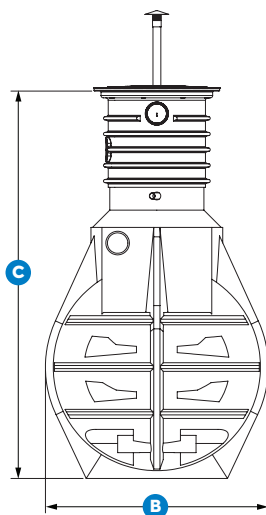
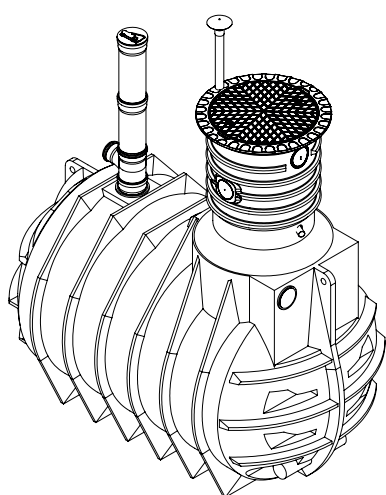

INSTALLATION

Solido Smart SBR requires a relatively low cost and easy installation process. The super-reinforced tank can be fully installed in free-flowing granular backfill and requires no concrete.

WARRANTY

All Premier Tech polyethylene tanks come with a standard 25-year warranty. Individual product and part warranties are available upon request.

Premier Tech works closely with a nationwide network of installation professionals. We proudly provide these partners with installation guidelines for each of our products.



PT Water and Environment

Quartertown Industrial Estate
Mallow, Co Cork
IRELAND P51 PY20

+353 (0) 22 51411
ptairl-sales@premiertech.com
PT-WaterEnvironment.ie



The information contained in this document was current and consistent with the information available at the time of publication. Premier Tech Ltd. makes no warranties or representations as to its accuracy. Because of its continuous improvement policy, Premier Tech Ltd. and its affiliated companies reserve the right to change and/or discontinue the manufacture of any product and/or modify technical data and prices, for any reason whatsoever and at its sole discretion, without further notice and without liability to anyone in this regard.

© 2020 Premier Tech Ltd. All rights reserved.
Printed in Ireland

Ireland
20200812